

Pneumatic activation enables minimal cycle time for 250 lbs. totes.

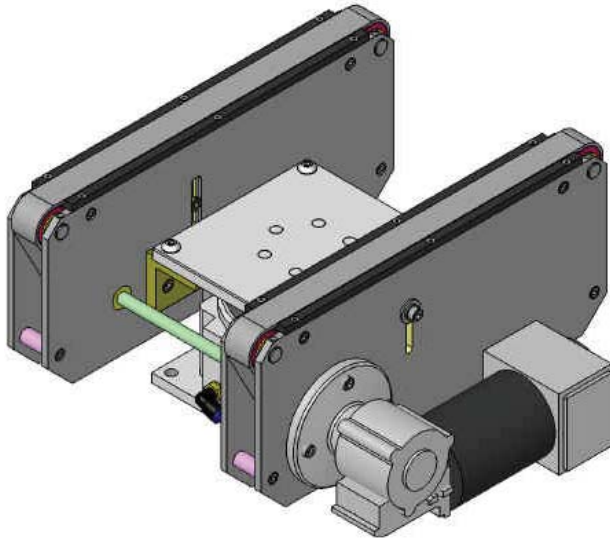

Key Functions

- Quiet and smooth operation
- Optimized cycle times to meet customer's throughput requirements
- Pneumatic activation enables transferring of totes up to 250 lbs
- Sensor detection for up and down positions
- Photoeye detect presence of tote
- Configurable belt quantities
- Field-bus or locally controlled

Specifications

Supply Power	24Vdc @5amp max.
Pneumatic Supply	50 psi
Pneumatic Activation	1.2" (30 mm) stroke
Divert Cycle Speed	3 sec.
Maximum Transfer Weight	250 lbs.
Linear Belt Speed	33 ft/min.
Mounting Option	Configurable with conveyor BF
Belt Pitch	9 inches (quantity and width customer specific)
Belt Width x Length	1" x 34.4" (25 mm x 875 mm)
Unit Weight	20 lbs.